

Ambassador / 600QD / 550 Operator's Manual

Arrow International
Equipment Division

B	1	2	3	4	5	6	7	8	9	10	11	12	13	14	15
C	16	17	18	19	20	21	22	23	24	25	26	27	28	29	30
M	31	32	33	34	35	36	37	38	39	40	41	42	43	44	45
G	46	47	48	49	50	51	52	53	54	55	56	57	58	59	60
Q	61	62	63	64	65	66	67	68	69	70	71	72	73	74	75

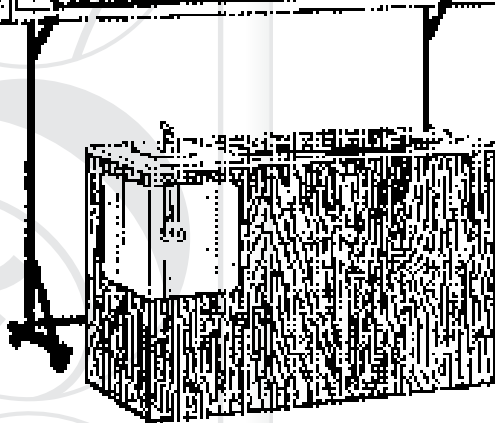

B	1	2	3	4	5	6	7	8	9	10	11	12	13	14	15
C	16	17	18	19	20	21	22	23	24	25	26	27	28	29	30
M	31	32	33	34	35	36	37	38	39	40	41	42	43	44	45
G	46	47	48	49	50	51	52	53	54	55	56	57	58	59	60
Q	61	62	63	64	65	66	67	68	69	70	71	72	73	74	75

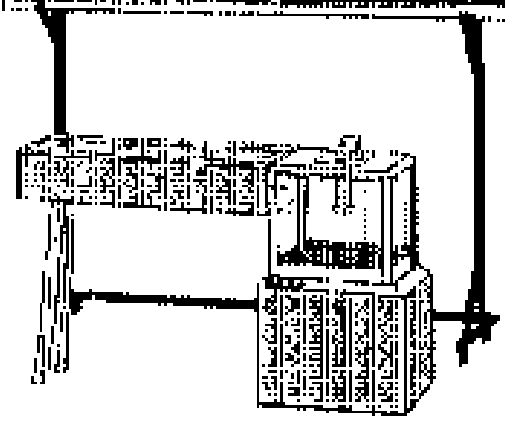

Thank you for choosing to purchase Arrow International's Capitol Bingo Equipment. We are confident that you will be completely satisfied with our high quality, durable bingo equipment. Our Capitol Bingo Equipment has the most technologically-advanced electronics and is designed for easy and reliable operation and trouble-free maintenance by the operator.

We are proud to announce that we have been given design and safety certification approval on all our bingo equipment from Underwriter's Laboratories, Inc. (UL). Arrow International, Inc. is the only bingo equipment manufacturer that has earned the UL approval certification. Look for the UL seal of approval on all our Capitol Bingo Equipment.

Arrow manufactures the highest furniture quality, hand crafted equipment consoles in the industry. Our metal fabricated steel consoles are constructed of the finest, heavy duty materials available and guaranteed to withstand many years of use.

This equipment manual introduces you to the Ambassador / 600QD / 550 Flashboards. It will take you step by step through unpacking your flashboard and the simple procedures for installation, set up and operation. Easy to follow instructions and illustrations allow you to perform routine service and maintenance.

Arrow's hard work and dedication enable us to offer you a breadth of product line that continues to grow. We are proud to offer you the most extensive charitable fundraising product line consisting of high quality, easy to open Popp-Opens™ tabs; "Top Shelf" banded jar tickets; the largest series of bingo paper available in the largest variety of colors, patterns and cuts to meet your game's needs; Tear Opens™; and our popular Wink® Ink, Ink-A-Dot™ and Electra Dot™ bingo markers. This dedication to providing an extensive line of high quality products is accompanied by our commitment to satisfying your product needs with fast and trouble free service.

We value you as a customer and always welcome and appreciate your comments and suggestions to help improve our products. Our best suggestions always come from our game operators and distributors. We want you to always be a satisfied customer, and we will continue to design and improve our products through the valuable feedback received from you and our reliable network of Arrow Distributors.

Once again, thank you for choosing Arrow International / Capitol for your charitable fundraising needs.

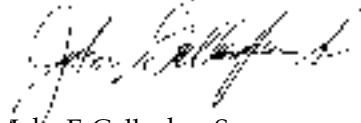

John E. Gallagher, Sr.
President



Introduction

This owners manual will introduce you to the Ambassador, 600 QD and 550 manual bingo systems. It will describe uncrating and hook-up procedures, illustrate how to get the most from the game and equipment features, and guide you through owner servicing and troubleshooting.

The Ambassador model is our top of the line non-electronic bingo system. Its modern design, wood-grained console and exceptional user convenience set it apart from the competition.

The 600 QD is our heavy duty non-electronic manual bingo system. Used in conjunction with our 450 blower, the 600QD system is a cost effective solution to meeting your basic equipment needs.

The 550 manual bingo display, our entry level bingo system, is a table top unit designed to be used with our 450B, 445 ball cage or equivalent. This system can be upgraded to either a 600 QD or an Ambassador and retain compatibility with its existing flashboard.

With each of these systems, the flashboard cables are easily connected to the console, and the user can operate all power switches from one console panel.

Table of Contents

Introduction	3
I. Unpacking	5
A. Ambassador Console	5
B. 600 QD Metal Masterboard	6
C. 450 Blower	6
D. 550 Manual Bingo Display	6
E. Flashboard	7
Warranty Assurance	7
II. Physical Installation	8
A. 600 QD Masterboard and 450 Blower	8
B. Wall Mounting Preparation for Flashboard	8
C. Wall Mounting Instructions	8
D. Ceiling Mounted Flashboards	9
E. Flashboard Stand	9
III. Electrical Installation	10
IV. Basic Controls	11
V. Operation	12
A. Ambassador and 600 QD Systems	12
B. 550 Manual Bingo Display	12
VI. Service	13
A. Cleaning your Bingo System	13
B. Changing Console Light Bulbs	13
C. Changing Flashboard Light Bulbs	14
D. Cleaning the Blower and Mixer	15
VII. Troubleshooting	17
VIII. Electrical Requirements	20
IX. Wiring Diagrams	20
Capitol Equipment Warranty	27

I. Unpacking

Arrow International designed our manual bingo systems to have a unique, attractive appearance. We used careful manufacturing and assembly techniques to preserve this appearance. Each system is inspected for scratches, bumps, or abrasions during packing and is warranted to be free from defects.

These systems are normally shipped in two or three cartons with the console, blower (if applicable) and flashboard packaged separately.

To avoid damage to your bingo system, please follow these unpacking instructions:

A. Ambassador Console

The Ambassador console is packed in a separate carton with foam inserts to protect it from damage during transit. The shipping carton is mounted on a skid. Check the carton for possible signs of damage and be sure to check inside the carton for damage.

Use scissors to cut the straps from the skid. Do not use a knife or other slitting tools as your cutting utensil. With assistance, carefully lift the console from the skid, cut the remaining straps from the console and remove the cardboard top. Next, remove the two foam protectors inside the top and slide the cardboard tube up and off the console. Lift from the top of the ball blower and grasp the two handles on the opposite ends to raise the console up and out of the carton. Check that all casters are in place.

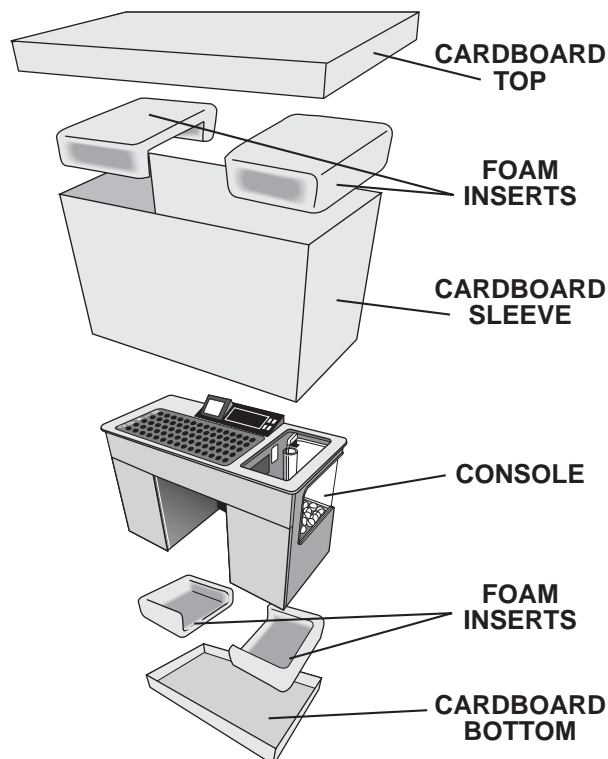

Damage Action Process

Your Capitol Bingo Equipment contains delicate electronic equipment. It is imperative that you thoroughly inspect the contents of the package before accepting from the carrier. In case of damage, make a note on the bill of lading before accepting, take a photo of the damage, and keep the packaging to aid in recovering the amount of claim against the carrier.

In case of severe damage, refuse the equipment from the carrier.

If the product is damaged but acceptable, take a photo before and after unpacking as a record of the damage and contact the carrier's agent immediately for inspection. Be sure to obtain a copy of the inspection report for your records.

If these precautions are not taken, we cannot assist you in recovering the amount of the claim against the carrier.

Caution: This console weighs approximately 170 pounds, get assistance before lifting.

Inspect your console for scratches, dents or any other physical defects. All acrylic panels should be in place. Metal panels and their associated switches and parts should be operational.

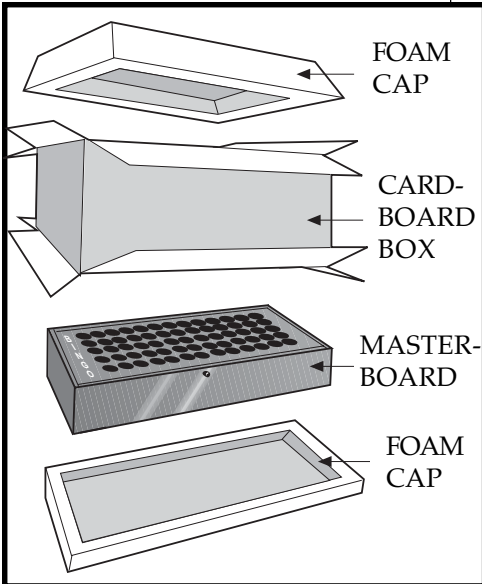

The following parts can be found inside the carton with the Ambassador console:

- (1) set white double numbered balls
- (1) customer parts kit which includes:
 - (4) ball switches
 - (4) #1820 28V Bulbs
 - (2) AGC 3AG 6amp fuses

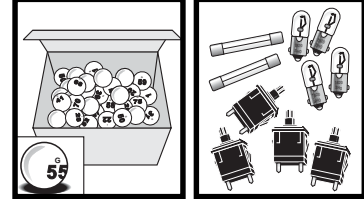

Open the box of bingo balls. Check each ball for damage and insert them into their corresponding slots in the console ball tray. If you find a ball with a flat spot, immerse it in hot water. Usually the flat area will pop out. If the ball is damaged, contact your Arrow distributor for a replacement.

B. 600 QD Metal Masterboard

The 600 QD masterboard is packed in a separate box with foam inserts to protect it from damage during transit. Inspect your masterboard for scratches, dents or any other physical defects.

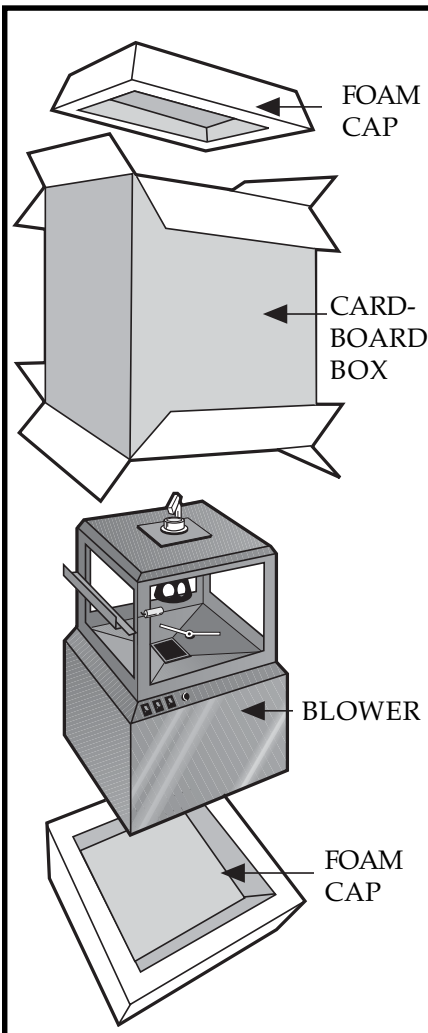

Caution: This masterboard weighs 47 pounds, get assistance before lifting.

With scissors, cut all packing straps and open the carton. Remove the blown in foam insert. Lift the 600 QD masterboard clear of the shipping carton. Next, carefully lay the masterboard on its side. At this time, inspect the 600QD for any damage or cosmetic defects.

C. 450 Blower

Your bingo ball blower is strapped into a heavy cardboard carton. Each carton is marked with various warning labels and stampings. Lay the carton flat, observing the labels displaying which side is up. Before opening, closely inspect the carton for evidence of shipping damage including puncture holes, tears, or crushed edges or corners. Damage to the carton may alert you to possible damage to the unit.

Caution: This ball blower weighs 54 pounds, get assistance before lifting.

Use scissors to cut all straps surrounding the carton. Do not use knives or other slitting tools as your cutting utensil. Lay the carton on it's side and cut the tape across the bottom. Open the bottom flaps and fold them outward. Stand up and lift the box clear of the blower. Remove the foam from around the blower

Next, open the box of double numbered bingo balls and check each one for possible damage. If you find a ball with a flat spot, a common remedy is to immerse the ball in hot water. Usually, the flat spot will pop out. If a ball is damaged, contact your Arrow distributor for a replacement. Empty your bingo balls into the ball retainer tray to insure that a complete set is present.

D. 550 Manual Bingo Display

The 550 Manual Bingo Display control console is packed in a separate box with foam inserts to protect it from damage during transit. Remove upper insert. Lift the 550 control console clear of the shipping carton. At this time, inspect the 550 for any damage or cosmetic defects.

E. Flashboard

Arrow International designed this system to have a distinctively attractive appearance, and we used careful manufacturing and assembly techniques to preserve this appearance. Each system is inspected for scratches, bumps or abrasions during packing, and is warranted to be free from defects.

The flashboard is banded into a heavy cardboard enclosure with foam inserts at each end and in the middle. This carton is marked with various warning labels and stampings. Lay the carton down flat, observing labels indicating which side is up.

Before opening, closely inspect the carton for evidence of shipping damage such as puncture holes, tears, and crushed edges or corners. Damage to the carton may alert you to damage to the flashboard.

Use scissors to cut all straps. Carefully lift off the carton top. Cut the tape on the four corners of the carton and lay the carton flaps down flat. Slide the end pieces off to allow access to the handles. Make sure the back of the unit is facing down on the cardboard to prevent scratching. Obtain assistance in setting the flashboard upright.

Do not destroy or discard carton materials until after final inspection and testing. Inspect the flashboard to insure that all plexiglass is in place and free of cracks or heavy scratches. Inspect the masonite panels for damage. If damage to your equipment is evident, or if you have problems in any of the above areas, contact your area distributor immediately for assistance.

The following parts can be found inside the carton with the flashboard:

- (1) Standard 100 ft. length of connecting data cable (other lengths optional)
- (1) Data cable adapter 6 inch.
- (2 - 4) J Brackets for mounting 2" and 4" flashboards only
- (1) Customer parts kit which includes:
 - (4) lightbulbs 1820 (1829 for 2" style boards)
 - (3) fuses AGC-3AG 3.2 AMP Slo Blo
 - (3) fuses AGC-3AG 4 AMP Slo Blo

IDII	B	1	2	3	4	5	6	7	8	9	10	11	12	13	14	15
	I	16	17	18	19	20	21	22	23	24	25	26	27	28	29	30
	N	31	32	33	34	35	36	37	38	39	40	41	42	43	44	45
	G	46	47	48	49	50	51	52	53	54	55	56	57	58	59	60
	O	61	62	63	64	65	66	67	68	69	70	71	72	73	74	75

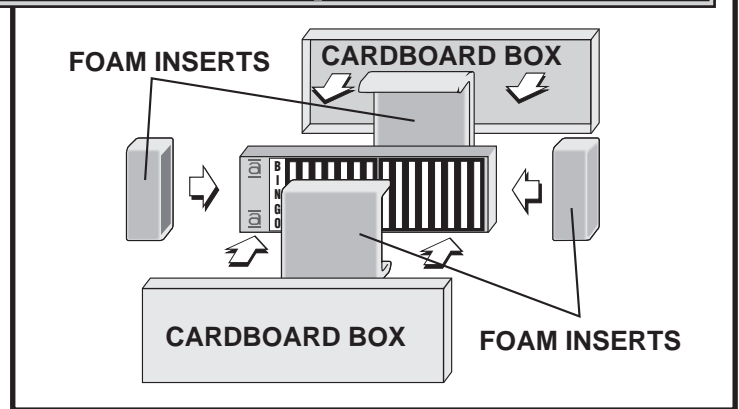

Note: If severe damage to the carton or flashboard is discovered, a photograph will provide an excellent record and may assist in processing claims against the carrier.

Caution: This flashboard weighs approximately 70 lbs. Obtain assistance before lifting.

Warranty Assurance

At this time, please verify the serial numbers and fill out the warranty cards. The numbers are located on the left side of the flashboard below the handle.

A second warranty card appears on the back cover of this manual. We suggest that you fill out this card and keep the information on hand for future reference.

II. Physical Installation

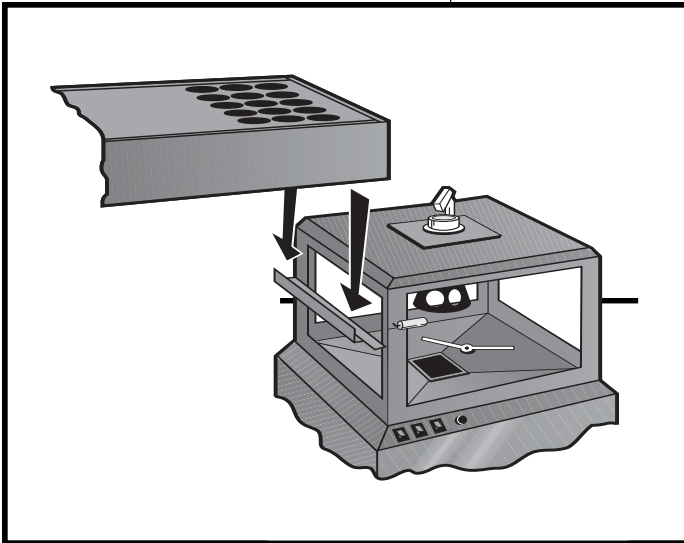

A. 600 QD Masterboard and 450 Blower

Assemble the 600 QD by pulling down the leg support for the masterboard and using the hooking supports on the 450 ball blower to connect it to the masterboard. Plug the masterboard power cord into the outlet on the ball blower, and plug the blower power cord into a standard 120 volt grounded wall outlet.

Optional accessories for these systems include covers for the system, a blower/masterboard dolly and modesty panel, console, flashboard, combination blower and masterboard, flashboard stand and wall mount. The masterboard and blower are placed onto this unit to make them easily portable and give the two systems the look of a console. These accessories are available from your local Arrow distributor. Please contact them for our latest catalog and pricing.

Caution: Before attempting any installation, have a qualified, licensed and bonded rigger or electrician verify the type of installation. In many cases, the local building inspector may require a permit as well as an inspection of the site for structural stability.

B. Wall Mounting Preparation for Flashboard

Before attempting to mount any flashboard to the wall, you must first determine the type of wall construction. With hollow walls, we recommend that the flashboard mounting brackets be fastened directly into wall studs. For concrete, brick and cinder block construction, the mounting brackets should be fastened using a bolt and anchor method (moly bolt). If other methods of wall construction are used, consider ceiling mounting or consult our service department.

Suggested No. of Flashboard Wall Mount Assemblies

SUGGESTED NO. OF FLASHBOARD WALL MOUNT ASSEMBLIES				
	PART NO.	NO.'S ONLY	NO. & GAME INDICATOR	NO., GAME INDICATOR & DOLLAR VALUE
2" Wall Mount	45253	2	2	3
J Bracket	415805	2	2	3
Eye Bolt	46515	2	2	3
4" Wall Mount	45254	3	3	4
J Bracket	415805	3	3	4
Eye Bolt	46515	3	3	4

C. Wall Mounting Instructions
Tubular Bracket (Optional)

(2" and 4" aluminum extruded flashboard and fabricated flashboard with tubular mounting brackets)

Choose the proper height for easy viewing and mark the location on the wall. This mounting bracket supports the flashboard from the bottom and may be used to mark the mounting holes. Place one bracket 9" from each end; make sure the brackets are level and remove any obstructions. Equally space the remaining brackets between the end brackets, insuring that all supporting surfaces are level. Drill the proper clearance holes for the mounting method appropriate for your wall.

D. Ceiling Mounted Flashboards (Optional)

In any ceiling application, the chain or wire must be attached to the steel building frame or girder. In addition, check with the local building inspector for local codes governing weight restrictions and mounting methods.

There are two different methods for suspending these flashboards from the ceiling.

1. Chain:

Use a high quality 3/8" chain or larger chain link made of high strength alloy, steel grade 80 or its equivalent. Bolt chain together with a 3/8" 18NC 1-3/4" bolt with two flatwashers, a lockwasher and a hex nut.

2. Wire:

Use a high quality 1/8" or larger diameter 19x7 strand steel aircraft cable or its equivalent and the appropriate wire clamp.

FLASH BOARDS	EYEBOLT LOCATIONS MEASURED FROM LEFT END			
	22"	46"	94"	118"
4" Dollar Value	22"	46"	94"	118"
4" Game Indicator	22"	38 3/4"	55 1/2"	72 1/4"
4" Numbers Only	17"	49"	76"	
2" Dollar Value	18"	36"	48"	
2" Game Indicator	18"	47"		
2" Numbers Only	12"	44"		

E. Flashboard Stand

A flashboard stand allows for easy mobility and storage of your flashboard. These stands fit all flashboards and may be ordered through your distributor.

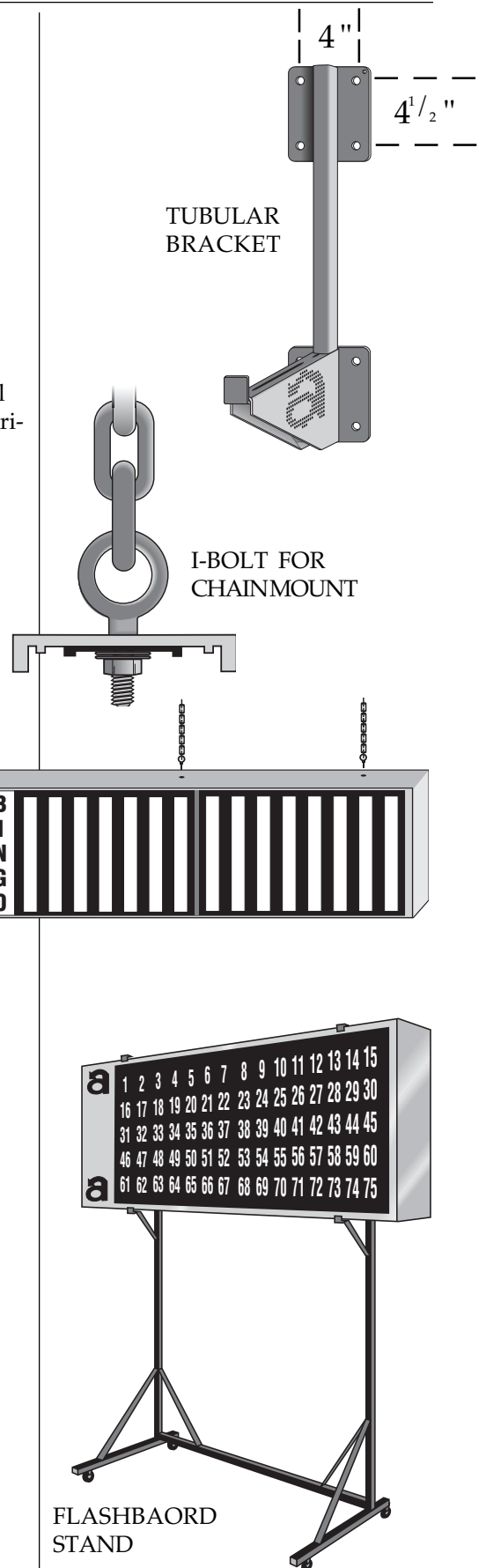

Note: When using the new style Ambassador components with older style components, the unidapter is required. Please consult Arrow's service department or your distributor for further information.

Note: When laying cable, avoid high traffic areas where the cable may be stepped on or tripped over.

III. Electrical Installation

1. Plug the Ambassador console power cord into a grounded wall outlet. For the 600 QD system, plug the 450 blower into a grounded wall outlet and the masterboard into the blower.
2. Plug the QD/Ambassador/550 flashboard into a grounded power outlet. Plug the flashboard data cable connections into the corresponding connectors on the console or masterboard.

FLASHBOARD CONNECTIONS FOR THE AMBASSADOR

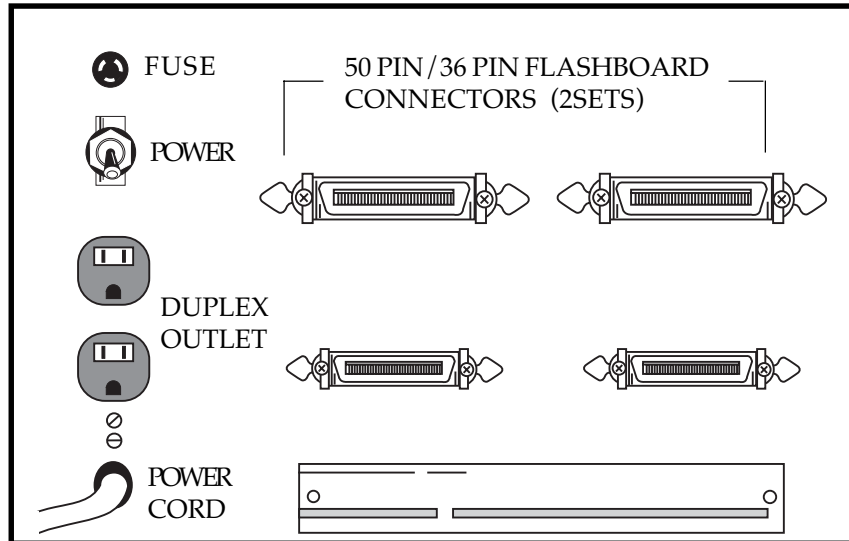

FLASHBOARD CONNECTIONS FOR 600QD

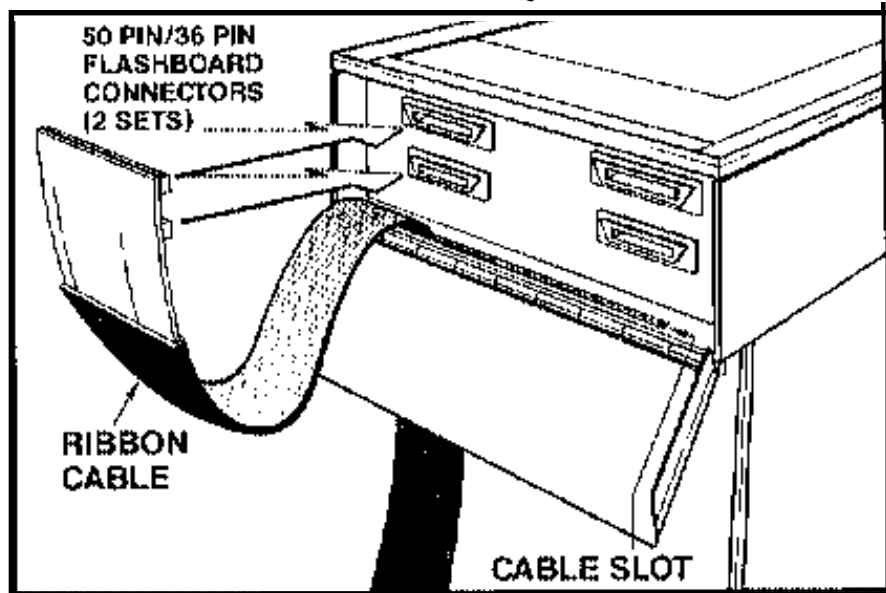

IV. Basic Controls

These controls are found on both the Ambassador and 600 QD (450 blower) systems:

1. Blower lamp On/Off—Controls blower chamber lamp
2. Mixer On/Off—Controls operation of mixer motor
3. Blower On/Off—Controls operation of ball blower motor

These additional controls are found on the Ambassador:

1. Main power switch—Controls power for console
2. Service lamp switch—Controls lamp in flashboard connector bay
3. An On/Off switch is mounted on the side panel of the QD/ Ambassador flashboard.

450 BLOWER CONTROL PANEL

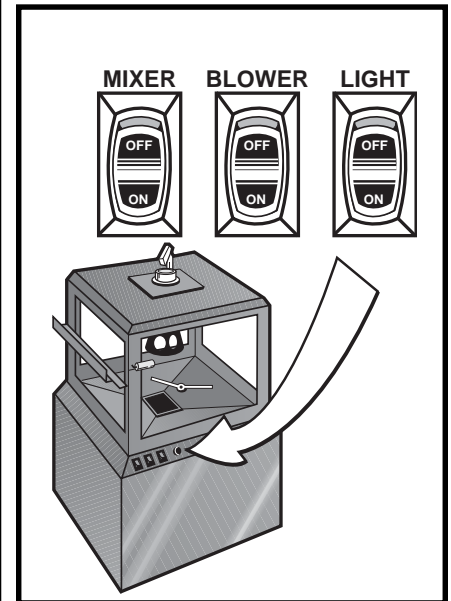

AMBASSADOR CONTROL PANEL

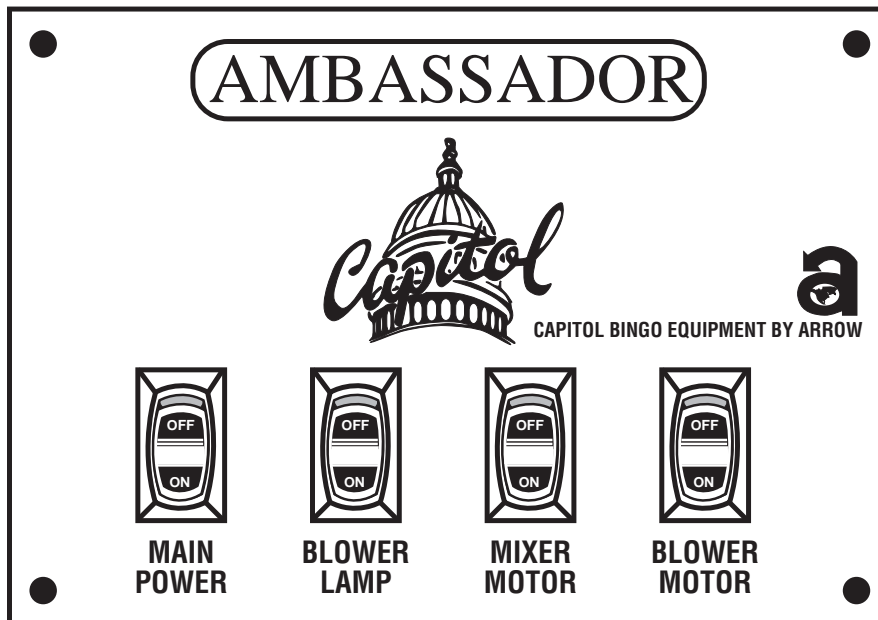

FLASHBOARD SIDE PANEL

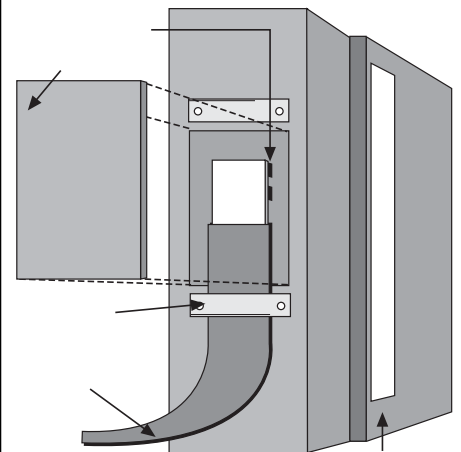

V. Operation

A. Ambassador and 600 QD Systems

To begin a bingo session, turn on the mixer switch, the blower switch and the blower light switch. You will notice that balls are immediately blown up the ball tube and held available in the holder.

To call a ball, remove the ball from the ball holder and insert it into the corresponding slot in the ball tray.

At the end of the game, firmly pull the handle at the bottom of the ball tray towards you against the stops to clear the ball tray and re-set the flashboard to game-ready status.

The knob pictured below must be turned counterclockwise to dump the balls back into the ball blower chamber. This gate acts as a security barrier in order to prevent accidentally dropped balls from re-entering the blower during a game. This gate also acts as a barrier to prevent the ball blower from accidentally blowing balls into the chute area during normal play and protects against balls re-entering the blower during a game.

Air pressure in the ball blower will prevent balls in the masterboard tray from dumping normally into the blower chamber. When this happens, briefly turn off the blower, allow the balls to drop, turn the blower back on and open the ball release to empty the remaining balls into the ball chamber. Check the ball return to verify that all the balls have returned to the blower.

BALL GATE RELEASE

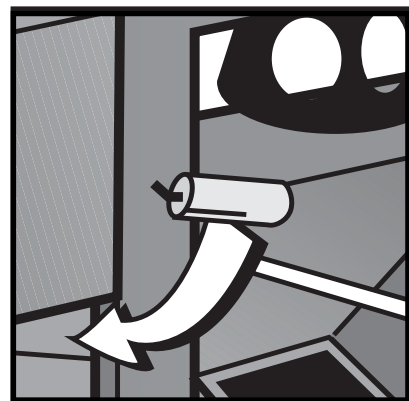

B. 550 Manual Bingo Display

Press each indicator button on the 550 consolette to light up the corresponding number on the flashboard. The switch is activated when the orange window is visible on the consolette button. When the game is finished, clear the flashboard by pressing the buttons again to close the orange windows.

VI. Service

A. Cleaning your Bingo System

Periodic servicing of your Ambassador 600QD and 550 systems should include cleaning, polishing and light bulb replacement.

Wood Consoles

Use any high quality wood and furniture polish. Apply with a soft cloth.

Painted Surfaces—Console and Flashboard

Use a mild soap solution or cleanser. Harsh cleansers or solvents may damage the paint or lettering. Follow with an automotive style polish.

Glass Surfaces—Console and Flashboard

Use a mild soap solution such as a liquid detergent with a clean, soft cloth.

Bingo Balls

Clean with a mild soap solution such as liquid detergent. Harsh cleansers or solvents may damage paint or lettering. Dry balls thoroughly.

Insert towel dried balls into a paper bag with talcum powder. Agitate ball and shake off excess powder.

Static Treatment

Lightly spray anti-static compound over the foam and inside the ball blower windows to eliminate static. Perform this treatment every few months or when the balls begin to stick together and to the windows.

B. Changing Console Light Bulbs

Ambassador Blower/Mixer Lamp

1. Open the blower chamber access door unplug the 4-pin harness from the blower base, then from the pan assembly and slide out the blower tray for easy access to the lamp.
2. Remove the plexiglass lamp panel covering the bulb by turning the two plastic tabs

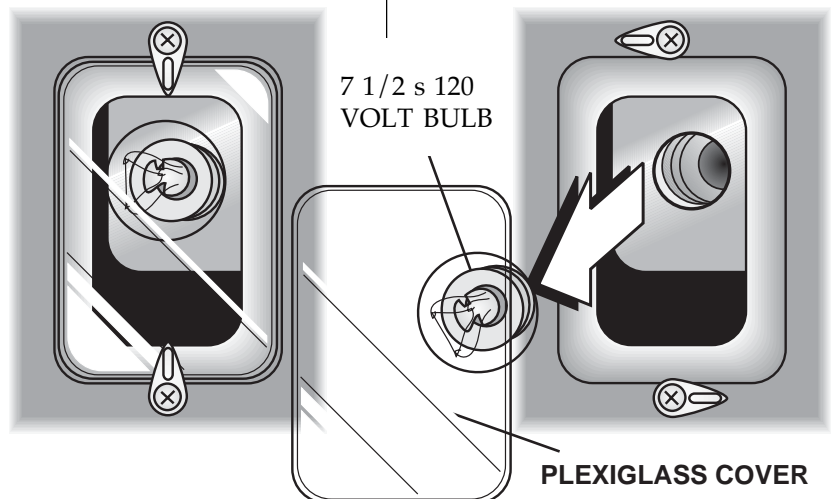

Caution: Over-spraying may remove polish from nearby painted or wood surfaces. The front of the glass is a painted surface.

Caution: Always unplug your system before performing any type of maintenance.

3. Turn the bulb counterclockwise to remove it.
4. Insert the new bulb and turn clockwise until snug. Do not over tighten.
5. Replace the plexiglass cover and resume operation.
6. Re-connect the blower power cable and slide the blower base pan assembly into place.

600 QD Blower/Mixer Lamp

Before replacing the light bulb in the ball blower chamber, unplug the unit from the wall.

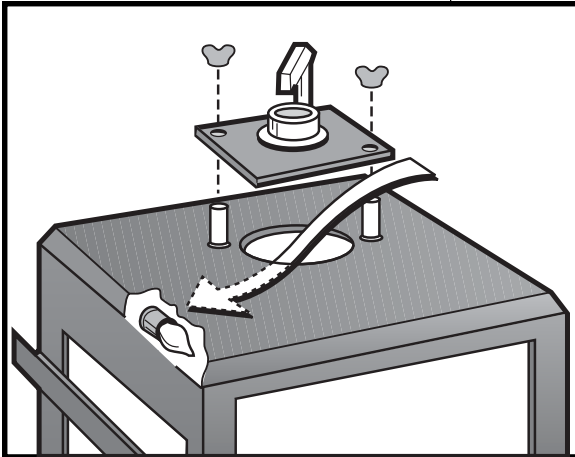

1. Remove the two wing nuts holding the ball catcher assembly, then pull out this assembly to gain access to the bulb.
2. Loosen the lamp socket retaining nut and slide off the protective lamp guard covering the bulb.
3. Change the bulb.
4. Reconnect the lamp guard to the lamp socket and tighten the retaining nut.
5. Replace the top of the ball catcher assembly and tighten the two wing nuts.

REMOVE TRIM WITH A PHILLIPS HEAD SCREWDRIVER AND SLIDE PANELS TO CHANGE BULBS.

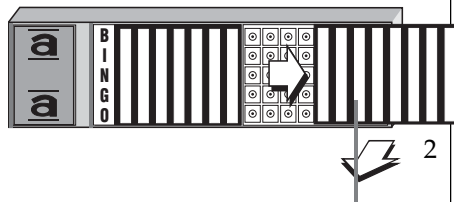
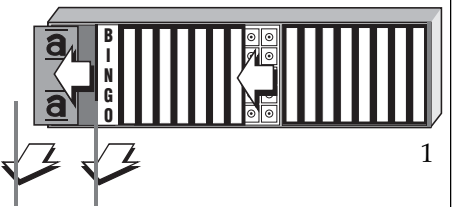

C. Changing Flashboard Light Bulbs

Change bulbs from the front side of the flashboard.

To change:

1. For low side bulbs (1-7), remove the (5) screws and the power pack cover and slide the plexiglass panel carefully to the left after removing the power pack cover. See drawing 1.
2. For high side bulbs (8-15), remove the metal strip on the right end and slide the panel to the right. See drawing B.

To change bulbs:

1. Turn power off.
2. Push bulb while turning counterclockwise. Socket is spring loaded.
3. Remove bulb from socket.
4. Re-insert new bulb in clockwise.

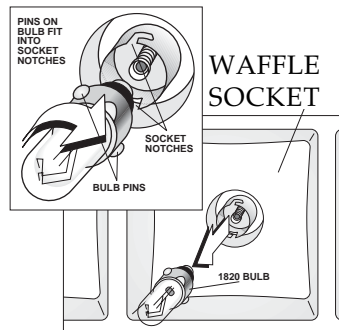
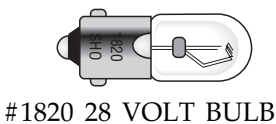

Additional bulbs may be purchased from your Arrow distributor or a local electrical or electronics supply house. When ordering replacement bulbs, ask for #1820 28-volt miniature bayonet light bulbs.

D. Cleaning the Blower and Mixer

Ambassador

The blower and mixer should be cleaned at least every four months or 200 operating hours to keep it performing properly.

1. Disconnect the blower cable wiring harness. slide the blower base out of the right side compartment of the console.
2. Remove the protective cover over the blower/mixer motors.
3. Put a few drops of 20W oil into the two oiling ports on the blower motor located on the top end and at the end of the mixer motor shaft.
4. Check the squirrel cage blades for debris. If dirty, remove the three outer casing screws and loosen the blade from the shaft with an allen wrench.
5. Clean with a brush, soap and water.
6. Re-assemble and carefully slide back into the console.
7. Make sure to re-connect the four pin power plug.
8. Clean inside the ball chute and right side compartment with a clean, soft cloth. You may use the same cleaner as used for the wood console.
9. Change the air filter as necessary.
10. With assistance, tilt the console to one side and clean the casters to keep them rolling freely. Oil them if necessary.

When ordering replacement ball chamber bulbs, ask for 7 1/2 S120 volt clear light bulbs (see illustration at right).

4 PIN POWER PLUG
(FEMALE RECEPTACLE)

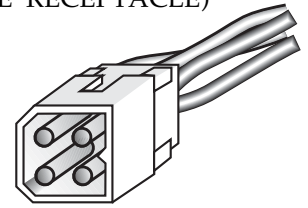

4 PIN POWER PLUG
(MALE RECEPTACLE)

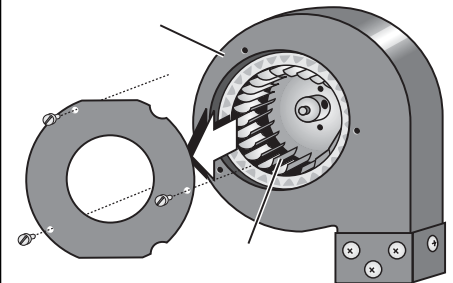
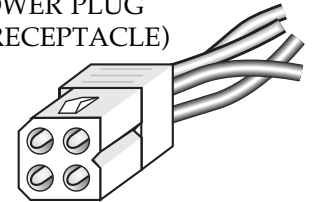

SQUIRREL CAGE BLADES

BLOWER MOTOR

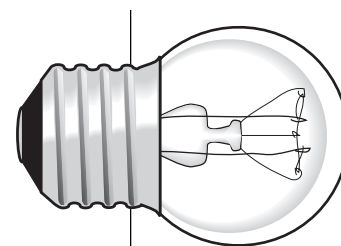
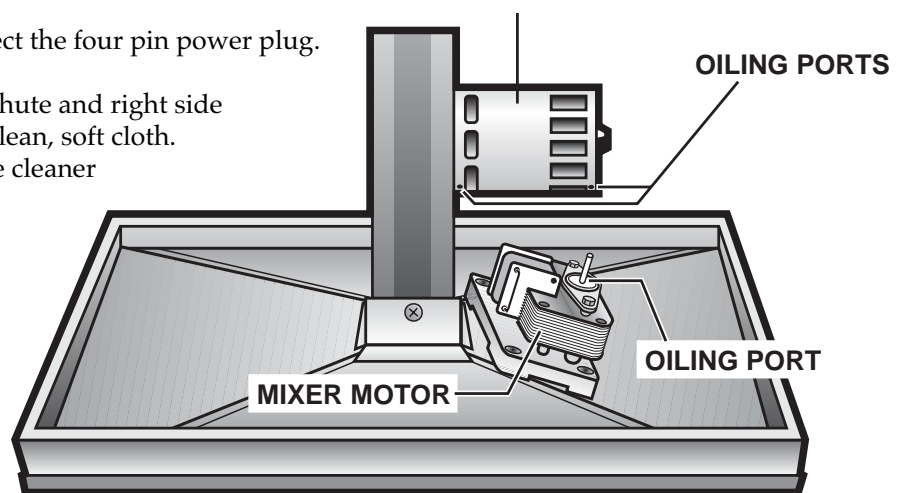

7 1/2 S
120 VOLT BULB

450 Blower

The blower motor and mixer motor should be lubricated every four months or every 200 operating hours. Access to the blower and mixer motors is gained through the bottom of the 450.

1. Remove the eight screws holding the bottom cover to the base.
2. Remove the protective cover over the blower/mixer motors.
3. Put a few drops of 20W oil into the two oiling ports on the blower motor located on the top end and at the end of the mixer motor shaft.
4. Check the squirrel cage blades for debris. If dirty, remove the three outer casing screws and loosen the blade from the shaft with an allen wrench.
5. Clean with a brush, soap and water.
6. Re-assemble and carefully slide back into the console.
7. Make sure to re-connect the four pin power plug.

VII. Troubleshooting

This section will help you, your distributor, or a local electrician locate electrical problems that may arise with your bingo system. Several diagrams and schematics have been included to help you trace any problems. Problems that are not covered in this section should be directed to your area distributor or directly to Arrow International.

Before referring to the table, please check to see that the following conditions are met:

1. Check all connections to system. Look for loose connections or broken wires. Do not attempt to service the control panel in the flashboard or console. Only trained service personnel are qualified to work in this area.
2. If flashboard difficulties arise, check all connections to the flashboard. If power is being supplied to the flashboard, the vertical B-O lamps should be on. If these lamps are not lit, then check the primary power to the flashboards.
3. Consult troubleshooting table.
4. If further difficulties arise, consult the factory service center or your distributor.

This troubleshooting table assumes the following conditions:

1. The system is plugged into a 120 volt grounded wall outlet.
2. The power switch is turned "ON".
3. All balls are in the ball tray.

The Troubleshooting Table begins on the next page.

This Troubleshooting table assumes the following:

1. The system is plugged into 120VAC wall outlet
2. The power switch is turned on.
3. All balls are in the ball tray.

Assumes the following conditions:

1. The console is functional
2. The unit is plugged into a 120VAC wall outlet
3. Power switch is on
4. All balls are in the console ball tray

<ul style="list-style-type: none"> • B-O lamps on with no response from console 	<ul style="list-style-type: none"> • Defective data cable • 1 Amp logic fuse blown • Defective PCB • Flashboard ACR Type PCB configured incorrectly • Using wrong FB for particular console 	<ul style="list-style-type: none"> • Repair or replace data cable. Check for loose or dirty connections and frayed or broken wires. • Replace fuse with a 1Amp slo blo ACG/3AG on ACRC PCB. Refer to page XX for access details. • Replace ACRC PCB in flashboard. Refer to page XX for access details. • Check W2 jumper setting, refer to pg. XX for proper setting for application • Consult factory
<ul style="list-style-type: none"> • No response to ball insertion in tray 	<ul style="list-style-type: none"> • Lamp failure • SCR/Darlington failure • Lamp Socket failure • Defective crimp on ribbon cable • ACRC PCB failure 	<ul style="list-style-type: none"> • Replace lamp in FB (use #1820 for 4" or #1829 for 2" board) refer to page XX for access details • Refer to map corresponding to style of PCB. Change SCR/Darlington. SCR's must be desoldered to be replaced. To replace a Darlington, use an IC puller or small screw driver to gently pry the darlington out of the socket. Use #41947 for darlington. • Check connections on back of lamp socket. Use ohm meter to check for a shorted lamp socket. (0 ohms) Replace defective socket. If good, meter will read about 22 ohms. • Check both ends of ribbon cable, re-crimp connection or replace ribbon cable. • Replace ACRC PCB. Refer to page XX access.
<ul style="list-style-type: none"> • Lamp stays illuminated when ball tray is cleared 	<ul style="list-style-type: none"> • Defective SCR/Darlington 	<ul style="list-style-type: none"> • Refer to appropriate map on page XX. • Change SCR/Darlington. Use #41947 for darlington.

	<ul style="list-style-type: none"> • Defective ACRC PCB 	<ul style="list-style-type: none"> • Change ACRC PCB. Refer to page XX for access details.
<ul style="list-style-type: none"> • Flashboard blinks or lights flicker 	<ul style="list-style-type: none"> • Loose data cable • Incorrect PCB configuration • Defective ACRC pcb 	<ul style="list-style-type: none"> • Check both ends of the data cable for loose connections or frayed wires. Replace sockets or cable as necessary. • Refer to Darlington map for corresponding PCB configuration. Set jumpers on ACRC PCB for specific application. • Replace ACRC PCB. Refer to page XX for access.
<ul style="list-style-type: none"> • Lights dim 	<ul style="list-style-type: none"> • Dirty plexiglass • Defective bridge rectifier • Low line voltage 	<ul style="list-style-type: none"> • Refer to page XX for cleaning instructions. • Check meter. Should read 28VDC + 1- 20% between the + and - terminal. Replace with 35A 800PIV Arrow part #41940 • Should read above 105VAC. Consult electrician.
<ul style="list-style-type: none"> • Group of 30 lights out 	<ul style="list-style-type: none"> • Defective secondary fuse 	<ul style="list-style-type: none"> • Refer to fuse map on page XX. Replace with a 3.2 Amp slo blo 3AGC/3AG fuse.

This Troubleshooting table assumes the following:

1. The system is plugged into 120VAC wall outlet
2. The power switch is turned on.
3. All balls are in the ball tray.

	<ul style="list-style-type: none"> • Defective cabinet lamp switch 	<ul style="list-style-type: none"> • Replace switch with proper rated switch (22A at 125VAC 16A at 250VAC Tungsten rated).
<ul style="list-style-type: none"> • Blower motor inoperative 	<ul style="list-style-type: none"> • Defective blower motor switch • Blower motor requires servicing 	<ul style="list-style-type: none"> • Replace switch with proper rated switch (16A at 125VAC 10A at 250VAC). • Oil motor. Refer to page XX for instructions.
<ul style="list-style-type: none"> • Defective blower 	<ul style="list-style-type: none"> • Check wiring and connection motor • Blower motor switch off • Blower cable loose 	<p>at motor. Refer to page XX for instructions. Replace blower motor if necessary. #41620</p> <ul style="list-style-type: none"> • Turn blower motor switch on. • Check 4 prong blower cable on console and all wiring on blower.
<ul style="list-style-type: none"> • Blower motor operates slowly 	<ul style="list-style-type: none"> • Blower motor requires servicing • Blockage of air intake 	<ul style="list-style-type: none"> • Oil blower motor. Refer to page XX for instructions. • Check air filter in console. If blower is on carpeting, raise the unit. • Check for debris or excessive dirt in blower and service as necessary. Refer to page XX for instructions.
<p>Note: Base foam will have to be changed. The four mounting screws for the mixer motor are located under the foam. To order a mixer motor, use Arrow part #41630. To order base foam for the console, use Arrow part #40820. To order base foam for the 450 blower, use Arrow part #40811.</p>		
	<ul style="list-style-type: none"> • Low line voltage • Defective blower motor 	<ul style="list-style-type: none"> • Check line voltage for minimum 108VAC. Consult electrician or local utility company. Voltage must be checked under actual game conditions. • Replace blower motor with Arrow part #41620.
<ul style="list-style-type: none"> • Mixer motor inoperative 	<ul style="list-style-type: none"> • Mixer motor switch off • Mixer motor seized 	<ul style="list-style-type: none"> • Turn mixer switch on. • Oil mixer motor. Refer to page XX for instructions.

VIII. Electrical Requirements

All systems 120 VAC 60 HZ

Ambassador Console

Total power required: 4 Amps, 480 W

Primary fuse rating: 6 Amp 3 AG

450B

Total power required: 4 Amps, 480 W

Primary fuse rating: 6 Amp 3 AG

QD Style Flashboard

Total power required: 3 Amps, 360W

Primary fuse rating: 4Amp Slo-Blo(3AG Slo-Blo)

Secondary fuse rating: 3.2 Slo-Blo (3AG Slo-Blo)

IX. Wiring Diagrams

Pinout for Older Models

QD Style Flashboard

Ambassador Console Primary

450 Blower Wiring

Connectors for Old Models

Pinout for New Connectors

PINOUT FOR OLDER MODELS

CONNECTOR	PIN NUMBER	BINGO NUMBER	COLOR CODE	CONNECTOR	PIN NUMBER	BINGO NUMBER	COLOR CODE
P2	1	B1	WHITE	P2	48	G48	YELLOW
P2	2	B2	BLUE	P2	49	G49	WHITE
P2	3	B3	WHITE	P2	50	G50	YELLOW
P2	4	B4	ORANGE	P3	1	G51	GREEN
P2	5	B5	WHITE	P3	2	G52	YELLOW
P2	6	B6	GREEN	P3	3	G53	BROWN
P2	7	B7	WHITE	P3	4	G54	YELLOW
P2	8	B8	BROWN	P3	5	G55	GRAY
P2	9	B9	WHITE	P3	6	G56	VIOLET
P2	10	B10	GRAY	P3	7	G57	BLUE
P2	11	B11	WHITE/BLK	P3	8	G58	VIOLET
P2	12	B12	BLUE	P3	9	G59	ORANGE
P2	13	B13	WHITE/BLK	P3	10	G60	VIOLET
P2	14	B14	ORANGE	P3	11	O61	GREEN
P2	15	B15	WHITE/BLK	P3	12	O62	VIOLET
P2	16	I16	GREEN	P3	13	O63	BROWN
P2	17	I17	WHITE/BLK	P3	14	O64	VIOLET
P2	18	I18	BROWN	P3	15	O65	GRAY
P2	19	I19	WHITE	P3	16	O66	BROWN
P2	20	I20	BLACK	P3	17	O67	ORANGE
P2	21	I21	RED	P3	18	O68	GREEN
P2	22	I22	BLUE	P3	19	O69	GRAY
P2	23	I23	RED	P3	20	O70	GREEN
P2	24	I24	ORANGE	P3	21	O71	BROWN
P2	25	I25	RED	P3	22	O72	ORANGE
P2	26	I26	GREEN	P3	23	O73	GRAY
P2	27	I27	RED	P3	24	O74	GREEN
P2	28	I28	BROWN	P3	25	O75	BLUE
P2	29	I29	RED				
P2	30	I30	GRAY				
P2	31	N31	RED				
P2	32	N32	BLACK				
P2	33	N33	BLACK				
P2	34	N34	BLUE				
P2	35	N35	BLACK				
P2	36	N36	ORANGE				
P2	37	N37	BLACK				
P2	38	N38	GREEN				
P2	39	N39	BLACK				
P2	40	N40	BROWN				
P2	41	N41	BLACK				
P2	42	N42	GRAY				
P2	43	N43	BLACK				
P2	44	N44	YELLOW				
P2	45	N45	BLK FROM BLK/VIOLET PAIR				
P2	46	G46	YELLOW				
P2	47	G47	BLUE				

NOTE: P1 USES 3 WIRES PER PIN

P1	1		VIOLET FROM BLACK/VIOLET PAIR
			BLUE
			BROWN
P1	2		BLUE
			GRAY
			VIOLET FROM WHITE/VIOLET PAIR
P1	3		BLUE
			ORANGE
			WHITE FROM WHITE/VIOLET PAIR
P1	4		YELLOW
			VIOLET
			YELLOW FROM YELLOW/RED PAIR

QD STYLE FLASHBOARD PRIMARY WIRING

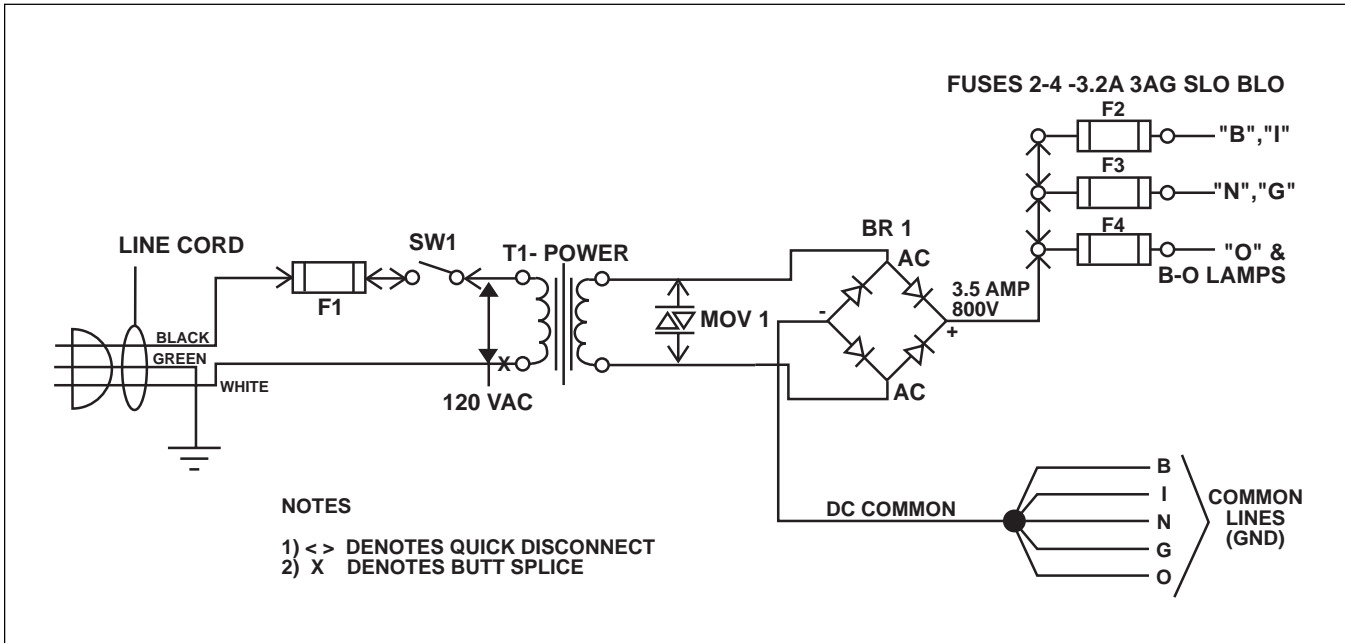

AMBASSADOR CONSOLE PRIMARY

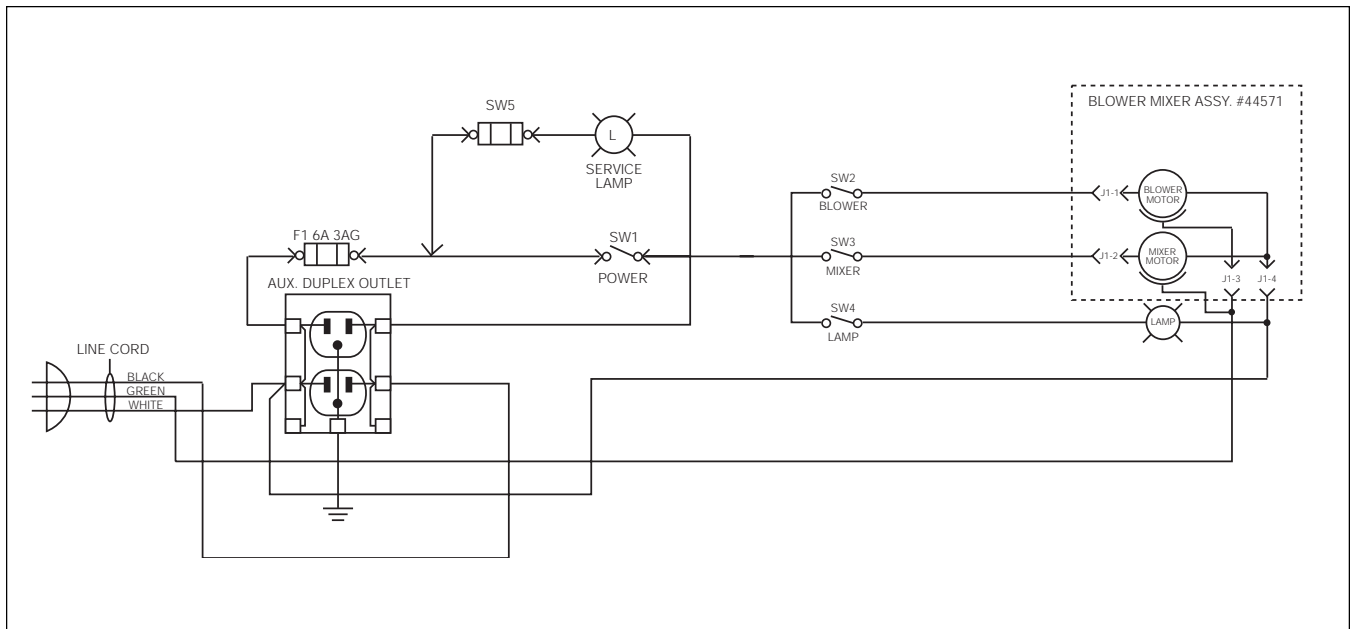

450 BLOWER WIRING

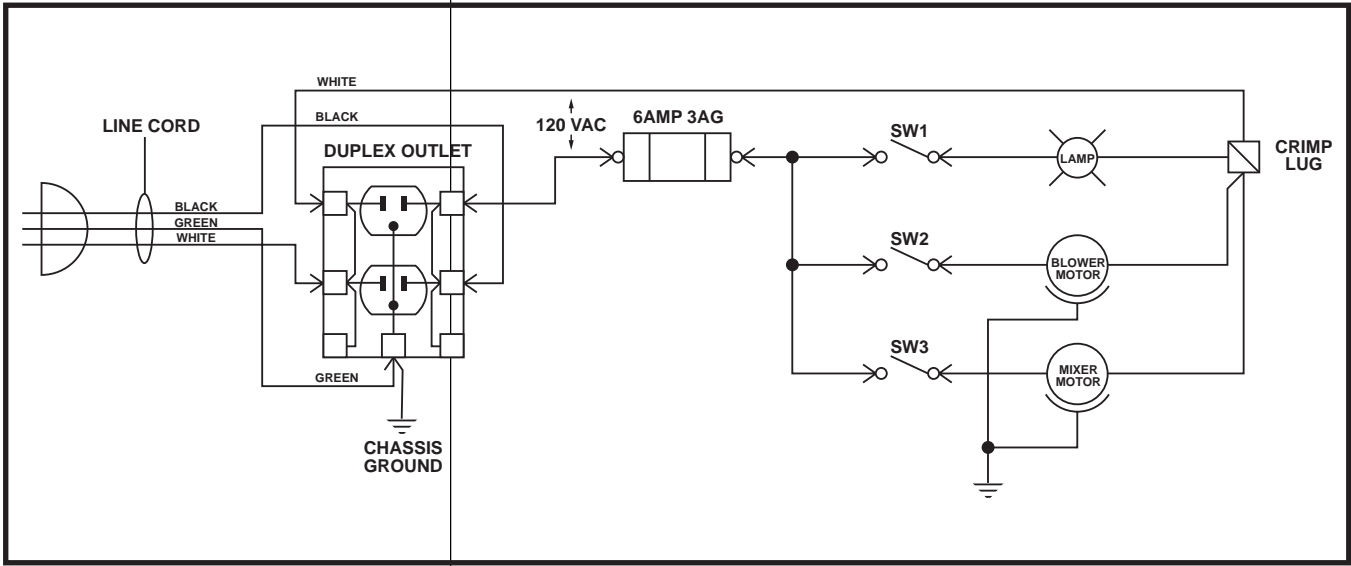

Connectors

connections from the console to the flashboard are made via three connectors:

P1
4 PIN
MOLEX

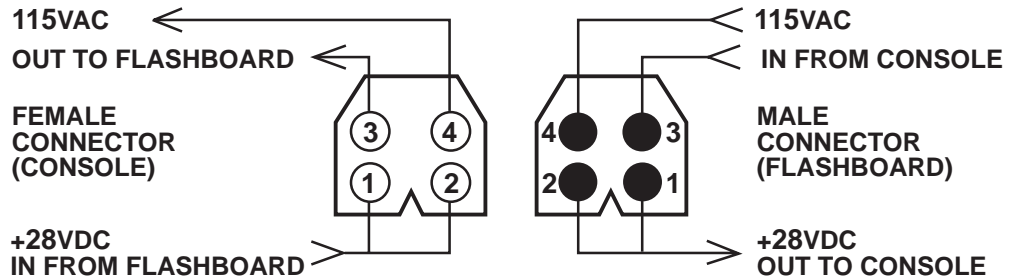

FIG. 6

P2
50 PIN
AMPHENOL
B1 to G50

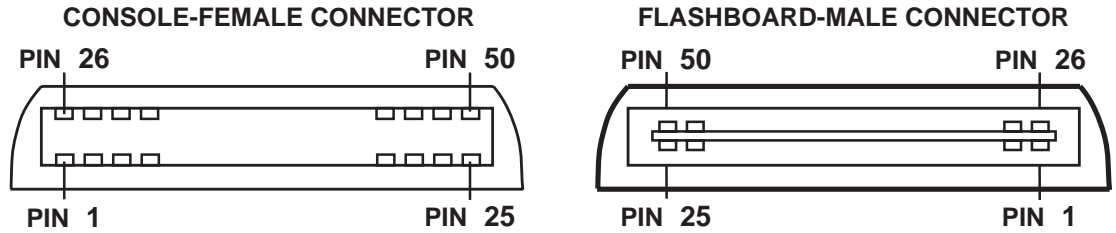

FIG. 7

P3
36 PIN
AMPHENOL
G51 to 075

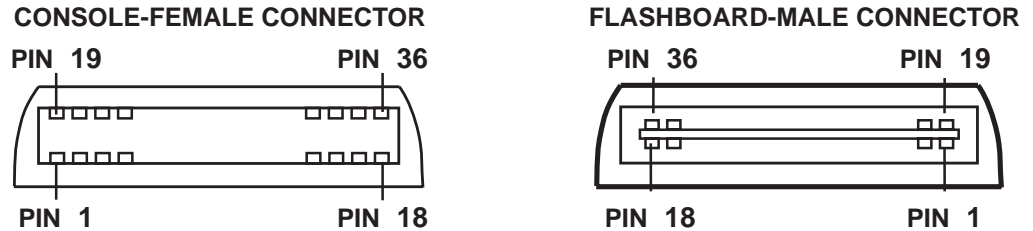
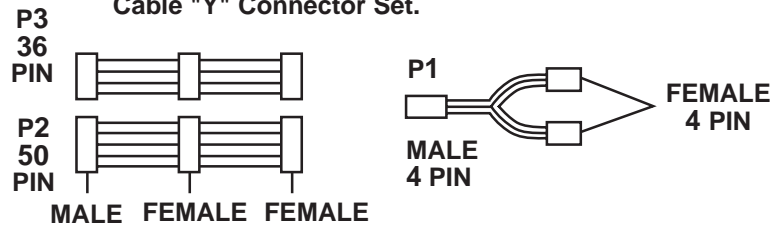

FIG. 8

To install a Satellite Flashboard, order the Ribbon Cable "Y" Connector Set.



AMBASSADOR AND 600QD SYSTEMS PINOUT FOR SWITCH AND LAMP MATRIX

<u>50 PIN CONN</u>	<u>FUNCTION</u>	<u>36 PIN CONN</u>	<u>FUNCTION</u>
J50-1	B1	J36-1	G46
J50-26	B2	J36-19	G47
J50-2	B3	J36-2	G48
J50-27	B4	J36-20	G49
J50-3	B5	J36-3	G50
J50-28	B6	J36-21	G51
J50-4	B7	J36-4	G52
J50-29	B8	J36-22	G53
J50-5	B9	J36-5	G54
J50-30	B10	J36-23	G55
J50-6	B11	J36-6	G56
J50-31	B12	J36-24	G57
J50-7	B13	J36-7	G58
J50-32	B14	J36-25	G59
J50-8	B15	J36-8	G60
J50-33	RTN	J36-26	RTN
J50-9	I16	J36-9	O61
J50-34	I17	J36-27	O62
J50-10	I18	J36-10	O63
J50-35	I19	J36-28	O64
J5011	I20	J36-11	O65
J50-36	I21	J36-29	O66
J50-12	I22	J36-12	O67
J50-37	I23	J36-30	O68
J50-13	I24	J36-13	O69
J50-38	I25	J36-31	O70
J50-14	I26	J36-14	O71
J50-39	I27	J36-32	O72
J50-15	I28	J36-15	O73
J50-40	I29	J36-33	O74
J50-16	I30	J36-16	O75
J50-41	RTN	J36-34	RTN
J50-17	N31		
J50-42	N32		
J50-18	N33		
J50-43	N34		
J50-19	35		
J50-44	N36		
J50-20	N37		
J50-45	N38		
J50-21	N39		
J50N-46	40		
J50N-22	41		
J50N-47	42		
J50N-23	43		
J50N-48	44		
J50N24	45		
J50-49	RTN		

Capitol Bingo Equipment Limited Warranty

Set out below are the terms of the Limited Warranty made by Arrow International, Inc. ("Arrow") in connection with the sale of the Capitol Bingo Equipment (the "Equipment").

1. Limited Warranty

Arrow warrants to the original purchaser ("Purchaser") that the Equipment will, for a period of one year from the date of original purchase from an authorized Arrow dealer, be free from manufacturing defects in material and workmanship. Purchaser represents to Arrow that no employee, agent, or representative of Arrow (or of an Arrow dealer) has made any representation or warranty regarding the Equipment except as set out herein.

THE WARRANTY CARD MUST BE COMPLETED AND RETURNED TO ARROW WITHIN 30 DAYS OF PURCHASE FROM AN AUTHORIZED CAPITOL BINGO EQUIPMENT DISTRIBUTOR FOR THIS LIMITED WARRANTY TO BE EFFECTIVE. A purchase receipt or other proof of date of original purchase must be submitted with the Warranty Card and will be required before warranty service is rendered.

This Limited Warranty applies to normal commercial use and does not cover damage which occurs in shipment; failures which are caused by products not supplied by Arrow, failures which result from accident, misuse, abuse, neglect, mishandling, misapplication, alteration, set-up adjustments or modifications. This Limited Warranty does not cover any damage to the Equipment resulting from failure to install in strict conformity with both local fire and building codes and regulations, or if installation does not comply with the installation instructions provided by Arrow.

2. Disclaimer of Warranties

Arrow makes no warranties, express or implied (including, without limitation, merchantability, fitness for particular purpose, or against infringement of any patent), except as expressly provided herein. The express warranties provided herein are in lieu of and exclude all other warranties, guarantees or representations, express or implied, whether arising by operation of law or otherwise.

3. Limitation of Remedies

If the Equipment supplied does not conform to the Limited Warranty set out above, Arrow will, at its option, (a) repair or replace the Equipment, or part thereof, which is defective or (b) refund so much of the purchase price as Purchaser has paid for the defective Equipment, less 1/24th of the purchase price for each month between the date of the purchase from an authorized Arrow dealer and the date of the discovery of the defect, provided that written notice of the defect and its nature is given to Arrow as soon as practical after discovery of the defect, but in no event later than 90 days from the date of the discovery of the defect.

4. Limitation of Liability

The remedy of repair, replacement, or refund of the purchase price is Purchaser's sole and exclusive remedy and will satisfy all of Arrow's liabilities, whether based on contract, negligence, tort, product liability, strict liability, or otherwise. **IN NO EVENT WILL ARROW BE LIABLE FOR INCIDENTAL OR CONSEQUENTIAL DAMAGES, NOR WILL ITS LIABILITY IN CONNECTION WITH ANY EQUIPMENT OR SERVICE SOLD (INCLUDING NONDELIVERY OR LATE DELIVERY THEREOF) EXCEED THE SALES PRICE OF SUCH EQUIPMENT OR SERVICE.**

5. Warranty Voided

Any obligations of Arrow under this Limited Warranty will be deemed to have been satisfied if anyone other than an authorized Capitol Bingo Equipment Dealer services the Equipment.

6. Transfer of Limited Warranty

Purchaser may transfer its rights under this Limited Warranty, subject to the terms and conditions hereof, to a buyer ("Buyer") from Purchaser of the Equipment. Thereafter, the rights under this Limited Warranty are not transferable. For the transfer by Purchaser of the Limited Warranty to be effective, the following conditions must have occurred no later than the 30th day following the date of resale to Buyer:

- A. Purchaser must have complied with all requirements to make the Limited Warranty effective as to Purchaser;
- B. The Equipment (as an entire unit and as purchased by Purchaser) must be transferred to Buyer; and
- C. Buyer must have submitted a new warranty card together with proof of purchase by Buyer from Purchaser.

Upon an effective transfer of this Limited Warranty, Buyer will be considered to be "Purchaser" for paragraphs 1 and 4 hereof.

7. Inspection

With respect to any claim that the Equipment is defective, Arrow will be allowed a reasonable time to inspect the Equipment, in place. If the Equipment is altered or removed before Arrow has made such inspection or waived its right to do so, the obligations of Arrow will be deemed to have been satisfied.

8. Limitation of Actions

Any legal action against Arrow for a default of its obligations under this Limited Warranty must be commenced within two years from the date the Equipment was sold by an authorized dealer of the Equipment.

9. How to Obtain Service

If a problem with this Equipment develops during or after the warranty period, proceed as follows:

- A. Refer to your Operator's Manual and follow the Troubleshooting Table within the "Service Section."
- B. Contact the authorized Capitol Bingo Equipment Distributor from whom you purchased the Equipment.
- C. Contact the Capitol Bingo Equipment Service Manager at the most convenient phone number listed below:

- 1 (800) 321-0757 outside Ohio, but within the U.S.A.
- 1 (800) 537-3479 within the state of Ohio
- 1 (216) 961-3500 within the 216 area code or
outside the continental U.S.A.
- 1 (216) 281-5250 FAX

SERVICE CALLS WHICH DO NOT INVOLVE DEFECTIVE MATERIALS OR WORKMANSHIP AS DETERMINED BY ARROW IN ITS SOLE DISCRETION, ARE NOT COVERED. COST OF SUCH SERVICE CALLS ARE THE RESPONSIBILITY OF THE PURCHASER.

Arrow wants you to remain a satisfied customer. If a problem occurs that cannot be resolved to your satisfaction, please contact us immediately. Phone one of the numbers listed above or write to:

Capitol Bingo Equipment Division
c/o National Service Manager
9900 Clinton Rd.
Cleveland, Ohio 44144

Please be sure to include the name, model number, serial number, date of original purchase, and the distributor from whom you purchased the Equipment, as well as any actions taken to correct the problem.

**You must return the enclosed
warranty card immediately in order
to insure proper warranty coverage.**

CUSTOMER WARRANTY CARD

CAPITOL BINGO EQUIPMENT OWNER REGISTRATION CARD

Model No _____ PCB No(s) _____

Serial No. _____ Date Purchased _____

Distributor Purchased From _____

Name of Organization _____

Address _____ Phone () _____

City _____ State _____ Zip _____

Chairman _____

Address _____ Phone () _____

City _____ State _____ Zip _____

Additional Information (Optional) ATTACH PROOF OF PURCHASE DATE

Purchase Price _____ Average Attendance _____

No. Of Night Games Played _____

Time Games Played _____ Average Spending Per Person _____

ARROW INTERNATIONAL, INC.

and our subsidiaries

CAPITAL GAME MANUFACTURING

METRO GAME MANUFACTURING

9900 Clinton Rd., Cleveland, Ohio 44144

1 (800) 321-0757 outside Ohio, but within the U.S.A.

1 (800) 537-3479 within the state of Ohio

1 (216) 961-3500 within the 216 area code or outside the continental U.S.A.

1 (216) 281-5250 FAX



© 1992 Capitol Bingo Equipment Division of Arrow International, Inc.